

Photovoltaic systems – Roof mounted

Property considerations for the peril of fire
July 2016



Author:

Zurich Global Risk Engineering Technical Center – Property

Cover photo source: Rich Gallagher, Zurich

Table of contents

1.	Executive Summary	1
2.	Introduction	1
2.1	The challenges	1
2.2	Document scope	1
3.	Discussion	1
3.1	Understanding the evolving hazards	1
3.2	Will the rate of rooftop fires increase with roof-mounted photovoltaic systems?	2
3.3	Will exterior building fire detection be needed?.....	2
3.4	Will rooftop photovoltaic systems increase the rooftop combustible loading?	2
3.5	Will photovoltaic power generation lead to defensive fire service tactics?	4
3.6	Will rack mounted photovoltaic systems provide concealed spaces for fire spread?.....	4
3.7	Will rack mounted photovoltaic systems increase roof cover flame spread?	5
4.	Guidance	6
4.1	Guidance and evolving systems	6
4.2	Develop corporate guidelines for photovoltaic systems .	6
4.3	Design phase.....	6
4.4	Installation phase	15
4.5	Operating phase.....	18
4.6	Fault or fire emergency response and recovery phase .	21
5.	Conclusion.....	22
6.	References	23
7.	Appendix A – Documentation.....	26
8.	Appendix B – Qualified person.....	27

1. Executive Summary

Photovoltaic systems have become part of the built environment. More and more buildings include photovoltaic systems installed on their roofs or integrated into their architectural features.

As with any electrical system, photovoltaic systems may introduce fire hazards. From an insurer's perspective, further work is needed to develop more comprehensive guidelines for the control of these hazards.

As this work continues, this document explores interim guidance a building owner or occupier may consider as they develop their approach to selecting, installing, and using photovoltaic systems.

In the early 20th century, electric power brought great benefit and fire hazards. Standards evolved to control the hazards.

In the early 21st century, a similar approach is needed with photovoltaic systems.

2. Introduction

2.1 The challenges

Photovoltaic systems installed on or integrated into buildings introduce a variety of potential challenges and increased risks. The challenges and increased risks may include:

- Increased fire ignition sources introduced on exterior building surfaces that are beyond the reach of fixed or automatic fire protection and fire detection systems typically provided inside buildings.
- Presence of solar power generation features that cannot be reasonably de-energized before fire suppression activities begin.
- Increased difficulty for fire department operations, with responding fire service making a reasonable decision to use defensive firefighting tactics to avoid placing personnel on roofs or within buildings equipped with photovoltaic systems.
- Increased flame spread or combustibility of roof coverings as the heat from a roof fire may be inhibited from dissipating upward away from the roof surface by the presence of rack-mounted photovoltaic modules.

2.2 Document scope

When photovoltaic systems are installed on or integrated into buildings, consider the guidance offered in this document for the design, installation, and use of these systems.

The focus of this document is the protection of property from the peril of fire. Considerations related to other perils – such as wind, snow, and hail, and lightning – do apply, but are beyond the scope of this document.

3. Discussion

3.1 Understanding the evolving hazards

Photovoltaic systems are an evolving technology. The installation or integration of photovoltaic systems onto or into buildings may introduce fire protection challenges that are not adequately understood today. Understanding may gradually improve through industry developments, research, and loss experience. The following questions highlight several of the perceived challenges with photovoltaic systems.

3.2 Will the rate of rooftop fires increase with roof-mounted photovoltaic systems?

Most buildings have some degree of electrical equipment on their exterior surfaces. When this electrical equipment fails it can turn into a source of fire ignition.

The installation or integration of a photovoltaic system onto or into buildings surfaces may increase the presence of electrical equipment. As with any electrical equipment, photovoltaic systems may be exposed to conditions such as physical damage, thermal stress, and corrosion that may lead to electrical faults and sources of fire ignition.



Figure 1 - With the installation of photovoltaic modules, in this example, the presence of rooftop electrics expands considerably compared to the pre-existing rooftop fans (Photo source: Rich Gallagher, Zurich)

Based upon Zurich US claims data for the ten year period from 2004 through 2013, the number of outside building fires of electrical origin was less than 1% of our overall fire loss experience. The question is whether the frequency of rooftop fires will increase with the presence of photovoltaic systems.

3.3 Will exterior building fire detection be needed?

Today, automatic rooftop fire detection is typically not provided. That makes sense considering the low loss frequency related to exterior fires. So, today, the detection of rooftop fires will typically depend upon manual detection such as a passing motorist or pedestrian.

Fires involving photovoltaic systems integrated onto or into building surfaces may occur beyond the coverage of traditional automatic fire protection and fire detection systems installed within buildings. Fire on exterior building surfaces may find pathways into buildings. However, the activation of internal fire alarms will likely be delayed, and the operation of interior fire protection systems will likely have minimal impact upon the external fire.

It may be appropriate to consider rooftop fire detection when photovoltaic systems are installed.

3.4 Will rooftop photovoltaic systems increase the rooftop combustible loading?

Photovoltaic modules may include noncombustible and combustible features. Noncombustible features may include the module face (glass) and frame (aluminum). Combustible features may include the module encapsulant (an elastomer such as ethyl vinyl acetate) and the backsheet (e.g. a polymeric material).

Zurich loss experiences where photovoltaic modules have been involved in fires indicate that combustible components have contributed as a fuel.

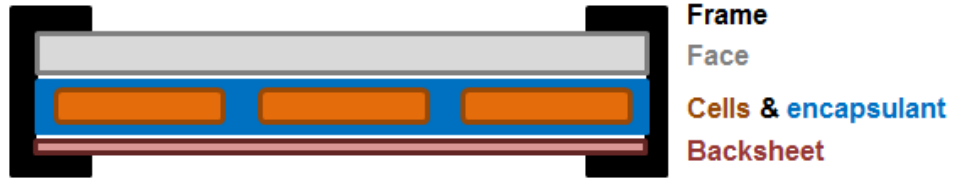

Figure 2 - Photovoltaic module cross-section (Image source: Rich Gallagher, Zurich)

Other combustibles present in a photovoltaic system may include cable insulations, junction boxes, polyvinyl chloride (PVC) conduits, and rubber support blocks.



Figure 3 - Insulated cables (Photo source: Rich Gallagher, Zurich)



Figure 4 - Junction box (Photo source: Rich Gallagher, Zurich)



Figure 5 - PVC conduit and rubber support blocks (Photo source: Rich Gallagher, Zurich)

3.5 Will photovoltaic power generation lead to defensive fire service tactics?

Before initiating firefighting activities, the fire service typically turn off sources of electric power to the building on fire, or at least the affected portion of the building. A complete shutdown of electric power may not be possible as photovoltaic cells continue to generate electric current as long as they are exposed to a light source. The presence of an uninterruptable power source may be perceived as a personnel safety concern to firefighters.

As stated in the Fire Protection Research Foundation report ***Fire Fighter Safety and Emergency Response for Solar Power Systems***, “Even with known shutdown steps taken to isolate electrical current, fire fighters should always treat all wiring and solar power components as if they are electrically energized.”

As the fire service is guided to assume photovoltaic systems cannot be fully de-energized, it is reasonable and realistic for the fire service to take measures to avoid exposing their personnel to unrevealed electrical hazards. This may cause the fire service to avoid aggressive modes of fire attack on or in buildings with photovoltaic systems. Instead, the fire service may transition to defensive modes of operation including exterior fire attack efforts and the protection of surrounding exposures.

3.6 Will rack mounted photovoltaic systems provide concealed spaces for fire spread?

The presence of rack mounted, rigid photovoltaic modules may shield large areas of roof surface from the direct application of water from overhead fire streams or elevated firefighting platforms. These shielded areas may allow fires involving the roof assembly to spread despite the presence of manual firefighting efforts. Zurich loss experience indicates that the presence of wind can aid the spread of fire through these concealed spaces.



Figure 6 - Shielded area below photovoltaic modules (Photo source: Rich Gallagher, Zurich)

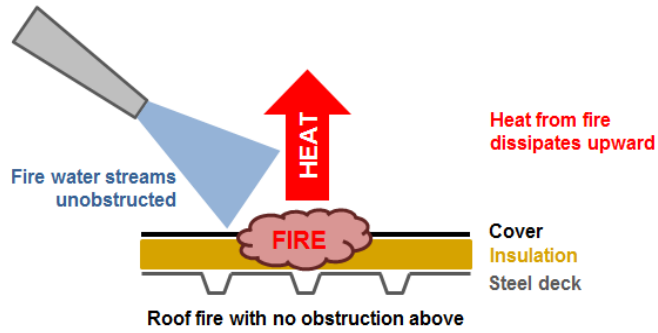

Figure 7 - Water application to an unobstructed rooftop fire (Image source: Rich Gallagher, Zurich)

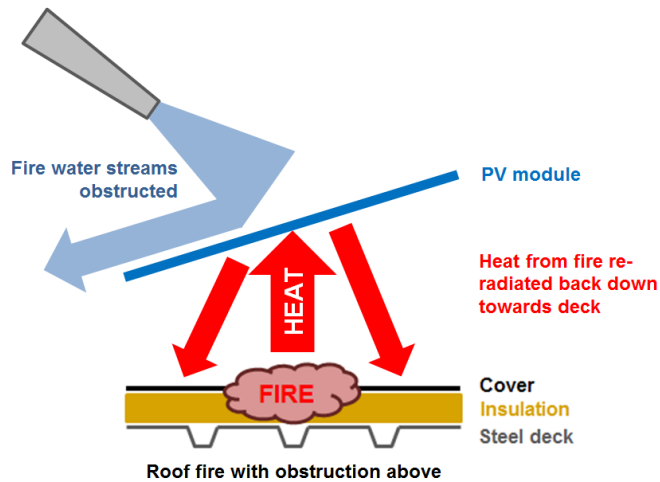

Figure 8 - Water application to an obstructed rooftop fire (Image source: Rich Gallagher, Zurich)

3.7 Will rack mounted photovoltaic systems increase roof cover flame spread?

Roof covering systems may include combustible materials such as asphalt, bitumen, rubber, and foamed plastics. These combustible materials are incorporated into roof cover and insulation assemblies which may be evaluated as a complete system by test agencies such as Underwriters Laboratories using test protocols such as **ANSI/UL 790, Tests for Fire Resistance of Roof Covering Materials**.

Historically, roof cover assemblies have been evaluated in fire situations with no feature present above the roof covering. During laboratory testing, heat from the fire and roof surface is allowed to freely dissipate upward and away from the roof surface under test.

Integrated fire testing of roof coverings with photovoltaic modules positioned above were conducted by Underwriters Laboratories in 2009. As discussed in the report **Effect of Rack Mounted Photovoltaic Modules on the Fire Classification Rating of Roofing Assemblies**, these tests demonstrated that the presence of photovoltaic modules above a roof cover may increase roof cover flame spread rates and the apparent combustibility of the roof system.

More recently, as discussed in the report **Fire Classification Rating Testing of Stand-Off Mounted Photovoltaic Modules and Systems. Solar America Board for Codes and Standards**, the **ANSI/UL 1703 Standard for Safety for**

Flat-Plate Photovoltaic Modules and Panels test protocol has been revised to incorporate a fire test integrating photovoltaic modules with specific roof assemblies. While this test protocol may provide useful information for general guidance, the results are not considered sufficiently informative from a property protection guidance viewpoint. Concerns include:

- The test protocol considers a fire scenario where the roof covering is ignited outside the boundary of the photovoltaic array. Fire ignition scenarios under the array are not addressed.
- One specific roof covering assembly is used for testing low-slope (flat) roofs. Real-world conditions may involve other roof covering assemblies that develop into more challenging fire conditions.

4. Guidance

4.1 Guidance and evolving systems

Since photovoltaic systems are an evolving technology, guidance related to photovoltaic systems is evolving as well. This evolution is based upon industry developments, research, and loss experience.

4.2 Develop corporate guidelines for photovoltaic systems

Building owners, and in some cases the building occupants, who have or plan to have photovoltaic systems should consider developing a corporate guideline reflecting a minimum set of requirements considered appropriate for their business. Zurich customers who prepare a corporate photovoltaic guideline are urged to review their corporate guideline with their Zurich account team.

A corporate photovoltaic guideline should consider measures to reduce the likelihood of a photovoltaic system fire occurring and measures to reduce the impact should a photovoltaic system fire occur.

A corporate photovoltaic guideline should address the following four phases across the life of a photovoltaic system:

- Design phase
- Installation phase
- Operating phase
- Fault or fire emergency response and recovery phase

Most guidance offered in this document falls under the Design Phase heading. The Design Phase offers the greatest opportunity to implement actions that may affect the performance of the system over its service life.

4.3 Design phase

As a new photovoltaic system is planned, consider the following measures to guide the system design phase.

4.3.1 One vendor

Select one vendor to design, supply, install, and maintain the photovoltaic system. The intent is to reduce questions regarding system responsibility over the life of the system.

4.3.2 Qualified person

Consider a requirement for the selected vendor to provide one or more qualified persons to be responsible for the photovoltaic system design, installation, and operation. While legal authorities may require personnel to be licensed or accredited for electrical installation and service work, the intent of this section is to pursue specific experience with photovoltaic systems. See Appendix B for information regarding qualified persons.

4.3.3 Location of photovoltaic systems

When choosing the location of a photovoltaic system, consider:

First choice: Install photovoltaic systems on the ground. See further guidance below regarding ground mounted photovoltaic systems.

Second choice: Install photovoltaic systems on building roofs formed entirely of noncombustible materials. See further guidance below regarding roof top photovoltaic systems.

Third choice: Install photovoltaic systems on building roofs that contain combustible elements. See further guidance below regarding roof top photovoltaic systems.

4.3.4 Ground level photovoltaic systems

This document is not intended to address photovoltaic systems installed at ground level; however, when installed on the ground level consider the following:

- Provide separation between photovoltaic systems and important buildings and structures.
- Provide concrete or stone surfaces below photovoltaic systems to help control or limit vegetation growth.
- Provide a perimeter fence and gates for access control. Provide fences at least 2.4 m (8 ft.) high. Lock gates with keys controlled by management.
- Provide vehicle impact protection features such as fencing, guard rails, or closely spaced concrete-filled metal pipes. Vehicle exposures may include lawn care equipment as well as motor vehicles.

4.3.5 Rooftop photovoltaic systems

Before placing photovoltaic systems on a building roof, consider:

- Impacts to flexible building use such as potential needs to:
 - Add rooftop utilities such as heating, cooling, and ventilation equipment
 - Extend vents through the roof for new heated equipment, plumbing systems, and exhaust systems
 - Access to conduct inspection and maintenance work for roofs and rooftop equipment
- Impacts to property and business should a rooftop photovoltaic system fire occur. For example:
 - Fire may damage a roof covering compromising its performance as a water-tight membrane.
 - Water may enter a building through a compromised roof covering. Water may damage the building, contents, and stock. During a rooftop fire, a likely source of water in large volumes will be fire service nozzles.

- Recovery from building, contents, and stock damage may take time leading to business interruption.

Where a photovoltaic system is to be installed on building roof, consider the following:

- Determine if existing roof coverings and insulations should be replaced before a photovoltaic system is installed. For example, a practice may be established to replace roof systems when the remaining service life of the roof system is not expected to exceed the service life of the photovoltaic system. The objective is to reduce the likelihood that a roof system will need replacement before the photovoltaic system. Roof system service life may be less of a concern for some roof systems such as metal structural standing seam systems and concrete tiles.
- Avoiding photovoltaic systems on roofs with any amount of expanded polystyrene insulation. Zurich loss experience indicates that even 12 mm (0.5 in.) of expanded polystyrene insulation may contribute to increased fire severity.
- For roofs with combustible elements, install noncombustible cover board such as gypsum board or mineral wool below the roof cover and above roof insulation to reduce the likelihood of a fire involving combustible roof insulations or decks.



Figure 9 - Placement of cover board in a roof assembly (Image source: Rich Gallagher, Zurich)

Cover board for low-slope (flat) roofs

Guidance to use cover board as a thermal barrier immediately below the roof membrane is recommended by organizations such as the National Roofing Contractors Association (Rosemont, IL, USA) when photovoltaic systems are installed on a roof.

The Property Insurance Research Group through the NFPA Research Foundation is pursuing a project to develop further insights regarding fire and roof mounted photovoltaic modules. It is anticipated this project may include further evaluation of cover board and its benefits.

- Provide a secondary watertight membrane below the cover board to reduce the likelihood of water entering a building should a fire occur. The primary membrane would be exposed above the cover board while the secondary membrane would be below the cover board. The intent is to allow the cover board to afford the secondary membrane a degree of protection should fire occur.



Figure 10 - Secondary membrane included

- Avoid locations where photovoltaic modules will experience periodic shading or shadowing due to higher roofs, trees, rooftop equipment of other similar features.

Shading and shadowing of photovoltaic systems

When an obstruction to sunlight shades a photovoltaic module its output is expected to be reduced. In addition, the higher output from unshaded modules on the same string may attempt to cause a backflow of electrical current into the shaded module. If permitted, the backflow current may cause heating of the shaded module. To avoid such heating, photovoltaic modules are equipped with bypass diodes.

Relying upon bypass diodes to control module heating when shaded is not desirable. As indicated in the TÜV Rheinland Energy and Environment GmbH report ***Bewertung Des Brandrisikos in Photovoltaik-Anlagen Und Erstellung Von Sicherheitskonzepten Zur Risikominimierung*** (*Review of fire risk in photovoltaic systems and creation of security concepts to minimize risk*), bypass diodes are subject to failure. Causes of bypass diode failure include surges due to lightning strikes.

Rather than relying upon bypass diodes, design rooftop photovoltaic system layout so modules will not be subject to shading or shadowing. During the operating life of the system, monitor the installation for the development of shading or shadowing sources. Sources may include growing vegetation, new rooftop equipment, or new buildings or structures.

4.3.6 Documentation

Establish a minimum documentation requirement for photovoltaic system design. See Appendix A for a list of documentation to consider.

4.3.7 Wiring practices

Providing guidance in the design documents to establish wiring practices intended to reduce exposures to electrical faults. Such practices may include:

- Cable end protection until connections are weather tight
- Cable handling practices to avoid insulation damage during installation
- Cable bending radius instructions based upon manufacturer guidance
- Cable connection instructions including:
 - Instruction regarding the use of compatible cable connectors
 - Instruction on the use of manufacturer recommended crimping tools to attaching connectors to wires

- Cable support for wiring not protected in conduit or cable trays
- Cable protection from physical injury
- Cable tray cover securement
- Providing conduit expansion couplings to accommodate the thermal effects of heating and cooling cycles on conduits. Thermal effects may place loads on conduits leading to joint failure and separation. Joint separation may expose cables to abrasion leading to electrical faults and possible sources of fire ignition.



Figure 11 - Example of a conduit expansion coupling (Photo source: Rich Gallagher, Zurich)

- Providing wire loops at junction boxes to avoid transferring loads from conduits to wires.
- Avoiding threads cut into metal conduit. Threading removes material from the conduit wall. Reduced wall thickness may also reduce corrosion resistance increasing the likelihood of a conduit failure at the cut threads. Such failures may expose cables to abrasion leading to electrical faults and possible sources of fire ignition.



Figure 12 - Example of a threadless coupling (Photo source: Rich Gallagher, Zurich)

- Avoiding the use of dissimilar metals where corrosion can potentially lead to electrical faults and sources of fire ignition.

4.3.8 Electrical fault detection and annunciation

Include design requirements for photovoltaic system monitoring to detect and annunciate electrical faults. Electrical faults such as ground faults and arc faults have been identified as causes of fires involving photovoltaic systems. Consider requirements such as:

- The installation of ground-fault sensing devices to detect faults
- The installation of arc-fault sensing devices to detect series arc faults
- Means to notify appropriate personnel of detected faults

4.3.9 Grounding

Follow local electrical codes and standards for:

- System grounding (e.g. grounded or ungrounded systems)
- Protective earthing (e.g. equipment grounding)

Photovoltaic systems and the word “grounding”

System grounding (or functional grounding)

System grounding is not to be confused with equipment grounding or protective earthing which is discussed below.

North America and Latin America generally install photovoltaic systems with one circuit conductor connected to ground. This is referred to as a “grounded system” or “functionally grounded system”.

Europe and Asia generally install ungrounded photovoltaic systems. NFPA 70, National Electrical Code®, has allowed ungrounded photovoltaic systems since 2005.

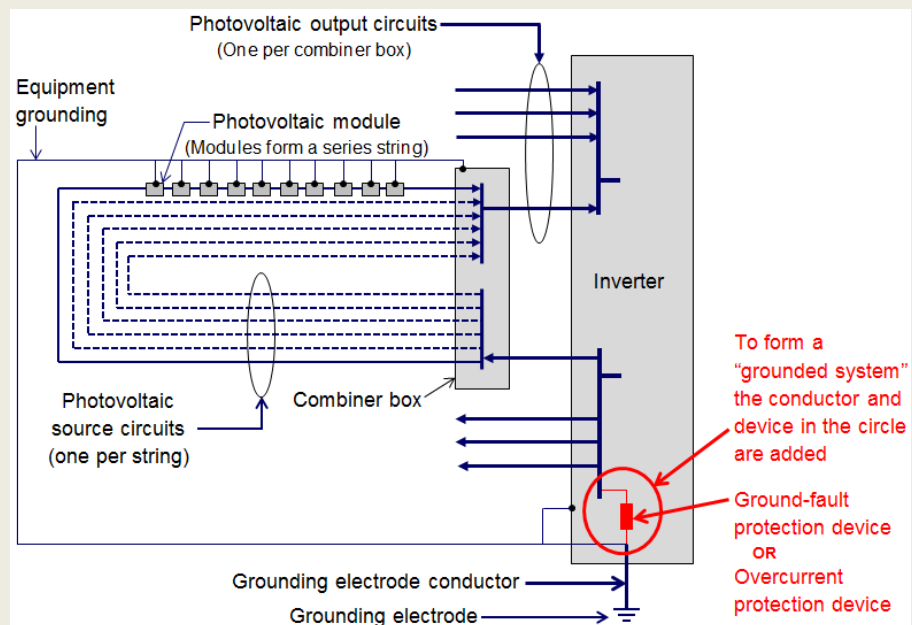

Schematic showing added wiring and device (in red) to form a grounded system (Image source: Rich Gallagher, Zurich)

Protective earthing or equipment grounding

The entire world generally requires grounding of metal system components that do not normally carry an electric current. This is known as protective earthing or equipment grounding. Protective earthing will typically include: photovoltaic module frames; photovoltaic module support racks; metal conduit; and metal enclosure housing components such as combiner boxes, disconnects, and inverters.

4.3.10 Fire detection

Consider the installation of a fire detection system to provide early warning of a fire involving photovoltaic systems. Options may include:

- Video smoke detection
- Triple IR flame detection
- Fiber optic heat detection

The photovoltaic fire detection system should be integrated into the building fire alarm system (if provided), and signals from the photovoltaic fire detection system should be monitored at a constantly attended location.

4.3.11 Material selection

Establish a minimum requirement for photovoltaic system materials and components.

- Select materials that are compatible for use together and rated for the intended service
- Select components that are approved, certified, or listed for their intended purpose by a Zurich Recognized Testing Laboratory

Zurich Recognized Testing Laboratories

Zurich Recognized Testing Laboratories are product certification bodies. They are qualified to perform self-accreditation of their product testing. Their services include product conformity certification, publication of a list of certified products, and a follow-up program to monitor the ongoing compliance of certified products.

Zurich Recognized Testing Laboratories are evaluated by qualified third-party accreditation bodies. Acceptable third-party accreditation bodies include members of the International Accreditation Forum, Inc. (see → http://www.iaf.nu/articles/IAF_MEMBERS_SIGNATORIES/4)

4.3.12 Codes and standards

Incorporate the requirements of the most recent editions of local codes and standards in the design and installation of photovoltaic systems.

Selected codes and standards addressing photovoltaic systems

The following is a list of selected codes and standard related to photovoltaic systems. It is not an exhaustive list.

- EN 61277, Terrestrial photovoltaic (PV) power generating systems - General and guide
- EN 62446, Grid connected photovoltaic systems – Minimum requirements for system documentation, commissioning tests and inspection
- IEC 62305, Lightning Protection Standard (this is a series of documents)
- NFPA 1, Fire Code; Section 11.12, Photovoltaic Systems
- NFPA 70, National Electrical Code; Article 690, Solar Photovoltaic (PV) Systems
- NFPA 780, Standard for the Installation of Lightning Protection Systems; Chapter 12 Protection for Solar Arrays
- VDE V 0126-1-1 Automatic disconnection device between a generator and the public low-voltage grid
- VDE-AR-E 2100-712 PV installation in case of firefighting

An example of firefighter roof access requirements

The image below is based upon NFPA 1, and is an example for a large, low-slope (flat) roof. Additional guidance is available for smaller buildings (e.g. dwellings) and pitched roofs.

The guidance establishes a clear roof perimeter as well as pathways between photovoltaic arrays (groups of photovoltaic modules). The darker shaded roof area could be used for additional photovoltaic modules; however, additional pathways would be needed as photovoltaic arrays are added.

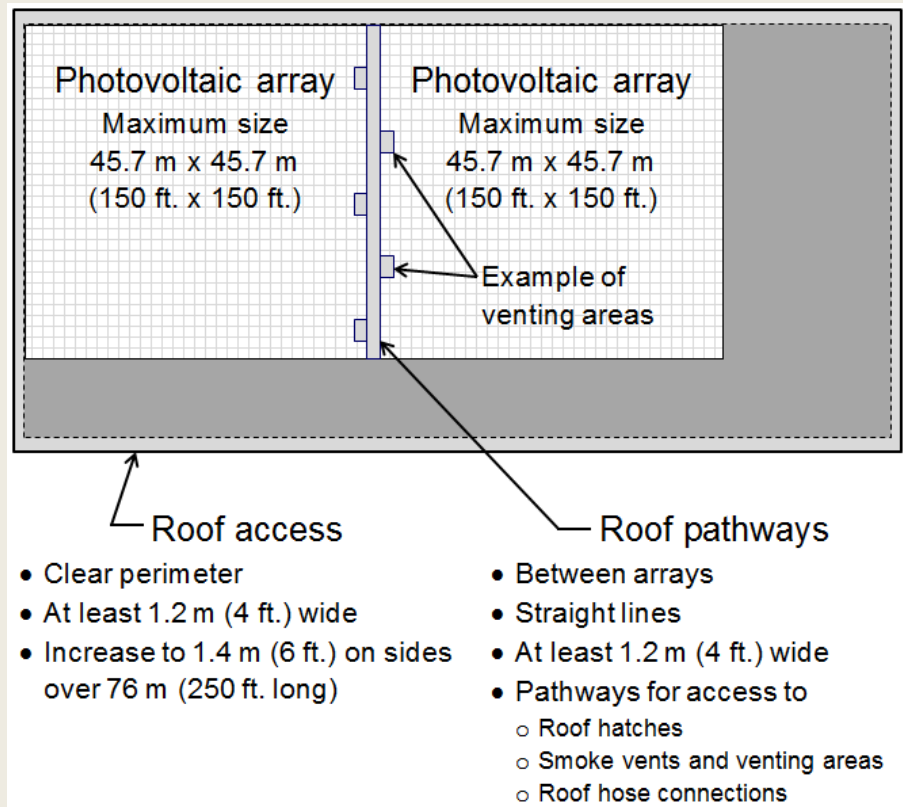

Example of firefighter access guidelines based upon NFPA 1 (Image source: Rich Gallagher, Zurich)

NFPA 1 requires pathways to be located where the roof has the structural capacity to support the weight of firefighters. In addition, DC wiring within pathways is to be minimized.

The NFPA 1 guidance is similar to guidance available in Germany for similar buildings where a 1 m (3.3 ft.) clear roof perimeter is stipulated and photovoltaic arrays are limited to 40 m x 40 m (131 ft. x 131 ft.).

4.3.13 Lightning and surge protection

Consider lightning protection and surge protection for locations vulnerable to lightning strike. Where Locations are vulnerable to lightning strikes, protection to more than just the photovoltaic system may be necessary.

Locations vulnerable to lightning

Zurich considers locations exposed to 4 to 10 lightning flashes per square kilometer per year (10 to 26 lightning flashes per square mile per year) as moderately vulnerable and locations exposed to more than 10 lightning flashes per square kilometer per year (more than 26 lightning flashes per square mile per year) as highly vulnerable.

Direct lightning strikes may cause immediate PV system damage. Surges induced by remote lightning strikes may contribute to PV system stress and lead to cumulative PV system damage. PV system damage from lightning strike activity could result in an ensuing PV system fire.

4.3.14 Plan review

Implement a plan review process to verify plans, specifications, and selected products for a proposed photovoltaic system are compliant with the established corporate guideline. See Appendix A for a list of documentation supporting the plan review process.

4.3.15 Existing systems

Where an existing system has completed the design phase without consideration of the guidance contained in this document (e.g. Section 4.3) consider a design review. The objective of the design review is to identify deviations from the guidance contained in this document as well as deviations from current local codes and standards.

Where the design review identifies deviations, assess each deviation to determine if it could increase the likelihood of system faults and fire inception hazards. For those deviations considered to increase the likelihood of system faults and fire inception hazards, develop and implement a mitigation plan.

4.4 Installation phase

As a photovoltaic system is installed, consider the following measures to guide the system installation phase.

4.4.1 Qualified person

Provide one or more qualified persons to be responsible for managing and supervising the photovoltaic system installation.

Verify qualified personnel are selected for the installation of the photovoltaic system.

See Appendix B for information regarding qualified persons.

4.4.2 Installation guidelines

Establish minimum requirements for photovoltaic system installation practices. This may include:

- Storage of components on site prior to installation in a manner that avoids contamination and physical damage.
- Handling of photovoltaic modules to avoid damage from impact, dropping, and flexing (consider a lifting and hoisting plan)
- Managing cables, conduits, and cable trays during installation.
 - Cable ends are protected until weather tight connections are formed.
 - Do not allow cable ends to sit in water (e.g. rain water) during installation
 - Cables are handled to avoid insulation damage.
 - Cable insulation may be damaged as the cables are pulled through conduit or pulled across edges or surfaces.
 - Cables are handled so they are not pinched between photovoltaic modules and their support racks.
 - Cable are not subject to a bending radius exceeding limits established by the manufacturer
 - Cable connections are secure.
 - Require the use of manufacturer recommended crimping tools for attaching connectors to wires
 - Cables not in a conduit or cable trays are supported to avoid flexing (e.g. due to wind) and abrasion (e.g. due to rubbing against adjacent materials such as a roof).
 - Cables are protected from physical injury by being located under photovoltaic modules, in conduits, or in cable trays
 - Cable tray covers are securely fastened

4.4.3 Supervision of installation work by owner or owner's representative

Implement visits during the photovoltaic system installation to verify the installation is following accepted system documentation. For example:

- Verify cable management practices as discussed in 4.4.2 above.
- Verify system components will be accessible for inspection and service
- Verify walkways are maintained free of obstructions
- Verify drain paths and drains are clear and unobstructed

4.4.4 Commissioning

Designate a representative to observe the commissioning process.

Develop and use a commissioning checklist, including inspection and testing elements such as those outlined in the list below. Customize the inspection and test elements based upon the specific installation including the type and number of components present.

- Inspection
 - Verify work is complete
 - Verify the installed components agree with the specified materials
 - Verify components are installed per the design documents
 - Verify circuit connections are complete, secure, and sealed
 - Verify equipment ground connections are complete and secure
 - Verify wiring is neat, secure, and protected from physical injury

- In the specific case of photovoltaic source circuits, verify condition such as:
 - Photovoltaic module leads are supported so they avoid transmitting loads to the module junction box
 - Wiring is supported to avoid flexing when exposed to wind
 - Wiring is supported to avoid contact with the roof
 - Wiring is protected from sharp edges and pinching
 - Wiring is protected with conduit or other suitable means when passing between module rows or beyond the module array
- Verify system component are mounted secure and show no signs of physical damage
- Verify required labels have been installed
- Verify any building penetrations are weather tight using a listed firestopping material
- Testing
 - Verify the polarity of each string
 - Measure and record the open circuit voltage of each string
 - Measure and record the short-circuit current for each string
 - Tests and record the insulation for each circuit
 - The intent of this testing is to:
 - Identify any cable insulations damaged during installation
 - Provide reference values for future ground fault troubleshooting
 - Thermographic inspection
 - Ground fault and arc fault triggering and monitoring
- Owner documentation and training
 - Verify a complete set of system documentation is provided to the owner
 - Verify owner education is provided to responsible staff
 - System operation
 - System disconnect sequence
 - System monitoring data
 - Maintenance practices
 - Fault response practices
 - Emergency response practices
 - Verify emergency and maintenance contact information is provided

Existing systems without suitable commissioning documentation

Thorough and well-documented commissioning records are an important indication an existing system began operating in a serviceable condition. Where thorough and well-documented commissioning records are not available for an existing system, a re-commissioning should be considered.

4.5 Operating phase

Once a photovoltaic system is in use, consider the following measures to guide ongoing photovoltaic system inspection, testing, and maintenance.

4.5.1 Monitoring

Establish a program for the monitoring of the photovoltaic system. The program should include among other things:

- A list of monitored conditions.
- A relative priority level for each monitored conditions. Specifically, identify conditions warranting immediate maintenance action and immediate notification of the public fire service.
- An automatic, electronic communication pathway to transmit monitored conditions from the photovoltaic system to a constantly attended monitoring location.
- Verification that qualified persons are assigned to monitor signals at the monitoring location. See section 4.5.2 below for a discussion regarding qualified persons.
- Actions to be taken by the persons at the monitoring location. Actions should be specific to each monitored condition. The actions should include notification of designated persons to respond to the monitored condition. The timing of the notification action should be based upon the assigned priority of the monitored condition.
- Actions to be taken by the persons responding to the monitored condition. The timing of the response action should be based upon the assigned priority of the monitored condition.

4.5.2 Qualified person

Provide one or more qualified persons to be responsible for the photovoltaic system inspection, testing, and maintenance activities. See Appendix B for information regarding qualified persons.

4.5.3 Roof access control

Establish practices to control access to roofs equipped with photovoltaic systems. The practice should include among other things:

- Assigning selected personnel with the authority to control roof access
- Requiring a qualified escort for persons accessing a roof who are not qualified to perform photovoltaic system design, installation, inspection, testing, or maintenance
- The qualified escort will be responsible to monitor the activities of escorted person(s) to minimize the likelihood of physical damage to the photovoltaic system components

4.5.4 Inspection

Develop an inspection program with inspection elements and frequencies based upon manufacturer and designer guidance.

Consider additional event-based inspections following storms (lightning, wind, hail, ice, snow, and sand), earthquakes, and other events that may adversely affect system integrity.

Develop an inspection checklist outlining specific observations to be conducted. Reports should define conditions indicating a normal state as well as conditions indicating a need for maintenance. Document each inspection with a report submitted to management where conditions requiring maintenance can be scheduled for timely repair.

- Verify circuit connections are:
 - Secure
 - Intact
 - Weather tight
 - Not physically damaged
 - Not showing signs of corrosion
 - Not discolored (e.g. signs of overheating)
- Verify equipment ground connections are:
 - Secure
 - Intact
 - Not physically damaged
 - Not showing signs of corrosion
- Verify wiring and cables
 - Secure
 - Intact
 - Not physically damaged including rodent damage
 - Not showing signs of corrosion
 - Not discolored (e.g. signs of overheating)
- Verify wiring supports are
 - Secure
 - Intact
 - Not damaging cable insulation
- Verify conduits and cable trays are:
 - Secure
 - Supported
 - Not showing signs of corrosion
 - Intact including:
 - Conduit joints
 - Cable tray covers
- Verify photovoltaic modules are:
 - Clean (e.g. no dirt or bird waste on the module face)
 - Secure
 - Not physically damaged
 - Not discolored (e.g. signs of deterioration or overheating)
- Verify other system components are:
 - Secure
 - Weather tight
 - Not physically damaged
 - Not showing signs of corrosion

- Verify rooftop housekeeping is controlled including:
 - No combustible debris is present on the roof (e.g. no leaves under photovoltaic modules)
 - No loose material or debris is present which could become airborne and damage photovoltaic system components
- Verify required labels are:
 - In place
 - Legible
- Verify points where the photovoltaic system penetrates the building remain firestopped

4.5.5 Testing

Develop a testing program based upon manufacturer and designer guidance.

Establish reporting requirements for test results. Reports should define conditions indicating a normal state as well as conditions indicating a need for maintenance. Document each test with a report submitted to management where conditions requiring maintenance can be scheduled for timely repair.

Consider an annual test program including:

- DC switch operation (operate switches 10 times to mechanically wipe corrosion from internal switch contacts)
- Testing and calibration of monitoring setpoint including arc fault and ground fault
- Electrical infrared testing. Conduct infrared testing of electrical components and wiring connections to identify loose electrical connections and failing components.
- Mechanical infrared testing. Conduct infrared testing of photovoltaic modules to identify temperature anomalies such as hot module junction boxes or hot cells within a module.

Electrical vs. mechanical infrared testing

Electrical infrared testing is used to locate and evaluate sources of elevated temperature in electrical equipment such as switches, circuit breakers, and wiring connections. The severity of a deficiency can be identified along with the likely mitigating action.

Mechanical infrared testing is used to assess temperature difference across an assessed object. The results may indicate the location of potential deficiencies; however, further information is likely needed to determine if actual deficiencies exist.

Mechanical infrared testing of photovoltaic modules is a new process. It is understood that methods to collect and organize data may be challenging, especially for larger systems. Some infrared testing vendors have indicated they are evaluating the use of drones to facilitate such testing.

4.5.6 Maintenance

Establish a maintenance program based upon manufacturer and designer guidance for both the maintenance activities and their frequency.

Additional maintenance action should occur where inspections or testing identifies abnormal conditions.

The maintenance program should include among other things:

- Pruning of vegetation to control photovoltaic module shadowing
- Cleaning of photovoltaic modules
- Checking torque at all termination points
- Checking fuses
- Cleaning the interiors of boxes and cabinets
- Checking inverter cooling fans and filters
- Testing the calibration and signaling of monitored conditions
- Replacement of components identified as deteriorated or damaged

4.5.7 Change management

Develop processes to manage modifications to photoelectric system installations. This should include consultation with a qualified person for guidance with changes. See Appendix B for a discussion regarding qualified persons.

In addition, this should include the submission of plans to Zurich for review and comment. Plan submissions should include all relevant documentation outlined in Appendix A.

4.6 Fault or fire emergency response and recovery phase

When a photovoltaic system fault or fire emergency is detected, consider the following measures to guide a timely and appropriate response.

4.6.1 Fault response

Under the Operating Phase, monitoring of photovoltaic systems was discussed (see section 4.5.1). The monitoring process included the establishment of list of monitored conditions as well as assigning priority levels to each monitored condition. The priority levels may span a range such as:

- Low priority faults including conditions which may reduce electric power output
- High priority faults including conditions indicating a source of fire ignition may be present (e.g. ground fault or arc fault)
- Fire alarms including conditions indicating a fire signature has been detected

When the monitored condition is a fault, develop action plans appropriate for the fault priority level. High priority faults should result in timely actions such as:

- Notification of designated parties
- Investigation of the fault by the appropriate notified persons
- Actions to eliminate the fault condition

4.6.2 Fire emergency response

Before a fire occurs, invite the local public fire service to the site to develop a written fire response plans. The fire service visit should allow them to:

- Become aware of the hazard associated with photovoltaic systems
- Become familiar the photovoltaic systems installed at the site including:
 - The locations of photovoltaic system disconnects
 - The operation of photovoltaic systems disconnects
 - The location of fire service rooftop access points and walkways
 - The location of inverter and grid connections
- Participate in the development of an emergency response plan for fires involving:
 - Photovoltaic systems
 - Building fitted with a photovoltaic system

When a fire is detected involving a photovoltaic system, the local public fire service should be promptly notified to initiate an emergency response.

4.6.3 Managing damaged photovoltaic modules (recovery phase)

Photovoltaic modules exposed to mechanical or thermal damage may continue to generate electricity. Fault and fire emergency response plans should include actions to handle and store damaged photovoltaic modules so they do not pose a hazard to buildings or structures.

4.6.4 Managing the replacement of photovoltaic modules (recovery phase)

When there is a need to replace one or more photovoltaic module, consult with a qualified person. The qualified person should:

- Verify the new modules are electrically compatible as part of the modified system.
- Perform re-commissioning to the extent appropriate. This includes tests verifying appropriate voltage and current levels are maintained.
- Update system documentation to reflect all revisions.

See Appendix B for a discussion regarding qualified persons.

5. Conclusion

Photovoltaic systems have become part of the built environment, and all indications are their use will continue to grow and expand.

As with any electrical system, photovoltaic systems may introduce new fire hazards. From an insurer's perspective, a range of actions should be considered to control these potential fire hazards.

This document shares a range of possible actions to consider across the service life of a photovoltaic system. This not only includes actions to consider during system design, installation, and operating, but also actions to consider during system faults, fires, and recovery.

Zurich customers implementing photovoltaic technology are urged to become informed and develop their own corporate guideline to manage photovoltaic systems. Consider the guidance provided in this document when preparing a corporate guideline.

As always, Zurich customers should consult with their Zurich account team for further guidance.

6. References

Mr. Tom Pedersen, IKEA, and Mr. Mark Gasper, IKEA. "IKEA approach to photovoltaic systems." Interview by Rich Gallagher, Zurich. 29 July 2015.

NFPA 1, Fire Code, Quincy, MA; NFPA, 2015. Online.

NFPA 70, National Electrical Code®. Quincy, MA; NFPA, 2014. Online.

NFPA 780. Standard for the Installation of Lightning Protection Systems. Quincy, MA; NFPA, 2014. Online.

Grant, Casey C. Fire Fighter Safety and Emergency Response for Solar Power Systems. Quincy, MA: NFPA Research Foundation, 2010. Web. Web accessed 20151106. <http://www.nfpa.org/research/fire-protection-research-foundation/projects-reports-and-proceedings/for-emergency-responders/fireground-operations/fire-fighter-safety-and-response-for-solar-power-systems>

Rosalie Wills, James Milke, Sara Royle and Kristin Steranka, Department of Fire Protection Engineering, University of Maryland, Commercial Roof-Mounted Photovoltaic System Installation Best Practices Review and All Hazard Assessment. Quincy, MA: NFPA Research Foundation, 2014. Web. Web accessed 20151105. <http://www.nfpa.org/research/fire-protection-research-foundation/projects-reports-and-proceedings/building-and-life-safety/fire-resistance/commercial-roof-mounted-photovoltaic-system-installation-best-practices-review>

Almand, Kathleen. Property Insurance Research Group Forum on PV Panel Fire Risk. Technical Notes. Quincy, MA: NFPA Research Foundation, 17 June 2014. Web. Web accessed 20160312

<http://www.nfpa.org/~media/files/research/research-foundation/foundation-proceedings/rfpvpanelhazardsinsurersforum.pdf?la=en>

Backstrom, Bob, and Mahmood Tabaddor, PhD. Effect of Rack Mounted Photovoltaic Modules on the Fire Classification Rating of Roofing Assemblies. Report. Northbrook, IL: Underwriters Laboratories, 2009. Fire Class Rating of PV Systems. Solar America Board for Codes and Standards. Web. Web accessed 20151105. http://solarabcs.org/current-issues/fire_class_rating.html

Backstrom, Bob, and Mahmood Tabaddor, PhD. Effect of Rack Mounted Photovoltaic Modules on the Flammability of Roofing Assemblies – Demonstration of Mitigation Concepts. Report. Northbrook, IL: Underwriters Laboratories, 2009. Fire Class Rating of PV Systems. Solar America Board for Codes and Standards. Web. Web accessed 20151105. http://solarabcs.org/current-issues/fire_class_rating.html

Kirby, James A., AIA. "Low-Slope Roofs as Platforms for PV Systems". SolarPro Issue 4.3, April/May 2011: 32-46. Web. Web site accessed 20160311. <http://solarprofessional.com/articles/design-installation/low-slope-roofs-as-platforms-for-pv-systems>

Sepanski, Annett, et. al. Bewertung Des Brandrisikos in Photovoltaik-Anlagen Und Erstellung Von Sicherheitskonzepten Zur Risikominimierung (Review of fire risk in photovoltaic systems and creation of security concepts to minimize risk). Cologne, Germany: TÜV Rheinland Energy and Environment GmbH, Mar. 2015. Web. Web accessed 20160317.

https://www.google.com/url?sa=t&rct=j&q=&esrc=s&source=web&cd=2&cad=rja&uact=8&ved=0ahUKEwiYlbvS2cfLAhVluYMKHfiyAYUQFggkMAE&url=http%3A%2F%2Fwww.pv-brandsicherheit.de%2Ffileadmin%2Fdownloads_fe%2FLeitfaden_Brandrisiko_in_PV-Anlagen_V01.pdf&usg=AFQjCNEaYbUdEy12tQPZCk6g2dx0NH7bHA&bvm=bv.117218890,d.amc

Brooks, Bill. The Ground-Fault Protection BLIND SPOT: A Safety Concern for Larger Photovoltaic Systems in the United States, A Solar ABCs White Paper. Solar America Board for Codes and Standards , 2012. Web. Web accessed 20151105.

<http://www.solarabcs.org/about/publications/reports/blindspot/pdfs/BlindSpot.pdf>

Brooks, Bill. Field Guide for Testing Existing Photovoltaic Systems for Ground Faults and Installing Equipment to Mitigate Fire Hazards, A National Renewable Energy Laboratory Field Guide, The Alliance for Sustainable Energy, LLC, National Renewable Energy Laboratory (NREL). 2013. Web. Web accessed 20151106.

www.nrel.gov/publications

Flicker, Jack, Jay Johnson. Analysis of Fuses for “Blind Spot” Ground Fault Detection in Photovoltaic Power Systems. Solar America Board for Codes and Standards , 2013. Web. Web accessed 20160319.

<http://www.solarabcs.org/about/publications/reports/blindspot/index.html>

Ball, Greg, et.al. Inverter Ground-Fault Detection “Blind Spot” and Mitigation Methods. Solar America Board for Codes and Standards , 2013. Web. Web accessed 20160319.

<http://www.solarabcs.org/about/publications/reports/blindspot/index.html>

McCalmont, Scott. Low Cost Arc Fault Detection and Protection for PV Systems. U.S. Department of Energy, National Renewable Energy Laboratory, 30 Sept. 2013. Web. Web accessed 20160318.

https://www.google.com/url?sa=t&rct=j&q=&esrc=s&source=web&cd=1&cad=rja&uact=8&ved=0ahUKEwiryvbnIMvLAhXktoMKHQxHBpUQFggdMAA&url=http%3A%2F%2Fwww.nrel.gov%2Fdocs%2Ffy14osti%2F60660.pdf&usg=AFQjCNELWeH23bUEw0-zYXMHL_jmdKNU8w

Rosenthal, Andrew, Larry Sherwood, Bill Brooks, Pravinray Ghandi, and Bob Backstrom. Flammability Testing of Standard Roofing Products In the Presence of Standoff-mounted Photovoltaic Modules. Flammability Testing of Standard Roofing Products in the Presence of Stand-off Mounted PV Modules — Solar ABCs Interim Report. Solar America Board for Codes and Standards. Web. Web accessed 20151106. <http://solarabcs.org/about/publications/reports/flammability-testing/index.html>

Sherwood, Larry, Bob Backstrom, Dwayne Sloan, Christopher Flueckiger, Bill Brooks, and Andrew Rosenthal. Fire Classification Rating Testing of Stand-Off Mounted Photovoltaic Modules and Systems. Solar America Board for Codes and

Standards. Web. Web accessed 20160701.

<http://solarabcs.org/about/publications/reports/flammability-testing/index.html>

Fisher, Jason, and David Brearley. "Ungrounded PV Power Systems in the NEC." SolarPro. Home Power Inc., Aug.-Sept. 2012. Web. Web accessed 20160318.

http://solarprofessional.com/articles/design-installation/ungrounded-pv-power-systems-in-the-nec?v=disable_pagination

Haney, Josh, Adam Burstein. PV System Operations and Maintenance Fundamentals. Solar America Board for Codes and Standards, 2013. Web. Web accessed 20160319.

<http://www.solarabcs.org/about/publications/reports/operations-maintenance/index.html>

7. Appendix A – Documentation

Specifications

- System description
- Applicable codes and standards
- Wiring and cable specifications
- Conduit (raceway) specifications
- Installation of conductors
- Installation of conduits (raceways)
- Wiring methods
- Monitoring systems
- Surge protection
- Commissioning plan and acceptance tests
- Operating instructions
- Inspection, testing, and maintenance instructions
- Management of corrosion and dissimilar metals

Manufacturer's literature

- Bill of materials (make and model of all system components)
- Product data including: description, approvals, selected options, and electrical ratings

Drawings

- Site plan
- Layout drawings (plan and elevation views as appropriate)
 - Module layout
 - String layout
 - DC switch, inverter, transformer, and AC switch layout
 - Wiring routes
 - Walkway location
- Photovoltaic module mounting assembly details
- Single line electrical diagram
- String wiring
- Protective earthing of equipment (equipment grounding)
- Combiner box wiring details
- Fire service system map providing information such as:
 - Location of the photovoltaic modules
 - Location of normally energized wires and components
 - Location of disconnect switches
 - Location of system components where power cannot be interrupted

8. Appendix B – Qualified person

The following insights are provided to explain the meaning of “qualified person” as used in this document.

A qualified person is able to provide a written statement of qualifications establishing their ability to develop an engineered solution for a particular application. The written statement of qualifications may include one or more of the following categories of evidence validating their qualifications:

Education

Educational qualifications should be based upon an accredited higher educational institution. Identification of accredited higher educational institutions is available through the UNESCO (United Nations Educational, Scientific and Cultural Organization) Portal to Recognized Higher Education Institutions web site.

See → <http://www.unesco.org/education/portal/hed-institutions>

Professional standing

The term “professional standing” is intended to include legally recognized designations such as Chartered Engineer (United Kingdom), Chartered Professional Engineer (Australia), European Engineer (Europe), Professional Engineer (United States).

Professional certification

There are many sources of professional certification. Certifications considered within the scope of this document are those issued by an organization accredited by a qualified third-party accreditation body. Qualified third-party accreditation bodies for the accreditation of certification organizations include members of the International Accreditation Forum, Inc.

See → http://www.iaf.nu//articles/IAF_MEMBERS_SIGNATORIES/4

Pertinent skills or knowledge

Pertinent skills or knowledge relate to capabilities that support the development of the proposed engineered solution. This could include proof points such as references, customer attestations, project lists, or references documenting or substantiating past work history, past projects, or special training experiences.

The Zurich Services Corporation
Risk Engineering
1299 Zurich Way, Schaumburg, Illinois 60196-1056
800 982 5964 www.zurichna.com

The information in this publication was compiled from sources believed to be reliable for informational purposes only. All sample policies and procedures herein should serve as a guideline, which you can use to create your own policies and procedures. We trust that you will customize these samples to reflect your own operations and believe that these samples may serve as a helpful platform for this endeavor. Any and all information contained herein is not intended to constitute advice (particularly not legal advice). Accordingly, persons requiring advice should consult independent advisors when developing programs and policies. We do not guarantee the accuracy of this information or any results and further assume no liability in connection with this publication and sample policies and procedures, including any information, methods or safety suggestions contained herein. We undertake no obligation to publicly update or revise any of this information, whether to reflect new information, future developments, events or circumstances or otherwise. Moreover, Zurich reminds you that this cannot be assumed to contain every acceptable safety and compliance procedure or that additional procedures might not be appropriate under the circumstances. The subject matter of this publication is not tied to any specific insurance product nor will adopting these policies and procedures ensure coverage under any insurance policy.

© 2016 The Zurich Services Corporation. All rights reserved.

